

## RI-F550 Series

### Multifunction Analyser - Single and Three Phase



- Power quality measurement
- DIN 96 panel mounted with IP64 front
- Real time clock, 8MB Memory with Event and alarm recording
- Full colour graphical display with 'touch' buttons
- Multi-tariff measurement
- Digital inputs and relay outputs
- Pulse output and Modbus communication
- Harmonics up to the 63rd
- Active energy EN62053-22 Class 0.2S
- Up to four additional plug-in modules
- Waveform capture, waveform display, phasor diagrams etc.
- 4 Tariffs
- Single or three phase network connection (TN, TT, TI)

#### Product Description

The RI-F550 Series is an advanced DIN 96 panel mounted multifunction meter with power analyser functions. Suitable for electrical parameter measurement and power quality analysis.

The meter has a full colour graphical display which provides clear indication in all light conditions.

Up to four plug-in modules can be added which allow the functionality of the meter to be extended with a wide range of both inputs and outputs. This enables full system integration with smart electricity distribution apparatus and energy management systems.

These meters may be used in single or three phase balanced or unbalanced load systems.

Quick select 'touch' buttons on the front of the meter allow the user fast access to the display page required.

#### Input and Output Features

The meter is equipped as standard with the following inputs and outputs:-

- RS485 Modbus
- Energy pulse output
- 2 x AC Digital inputs
- 2 x Relay outputs
- Neutral current transformer input

In addition to these core features the meters functionality can be expanded by the use of plug-in modules.

#### Plug-in Modules

The RI-F550 Series are provided with two connection points, each of which can accommodate two extension modules. This means that up to four modules may be connected per meter.

Module	Description
RI-A5DCDI	4 x DC digital inputs
RI-A5RO5A	2 x relay outputs
RI-A5DCAI	2 x analogue inputs : mA
RI-A5PT100	2 x analogue inputs : PT100
RI-A5DCAO	2 x analogue outputs : mA
RI-A5ETNT	Ethernet, Modbus/TCP
RI-A5PROF	DB9, Profibus-DP
RI-A5RS485	RS485, Modbus-RTU
RI-A5RSBAC	BACnet RS485
RI-A5IPBAC	BACnet TCP/IP

## Measurement

The list below shows which electrical parameters can be measured by the meter.  
This includes relative variables calculated from basic electrical parameters.

Measurement Variable	Designation	Instant	Max.	Min.	Demand	Sum	Unit
Voltage phase to neutral	V1-N / V2-N / V3-N / Vavg	✓	✓	✓	-	-	V, kV
Voltage phase to phase	V1-2 / V2-3 / V3-1 / Vavg	✓	✓	✓	-	-	V, kV
Phase current and demand	I1 / I2 / I3 / Iavg	✓	✓	✓	✓	-	A, kA
Neutral current	In	✓	✓	✓	-	-	A, kA
Frequency	F	✓	✓	✓	-	-	Hz
Phase active power	P1 / P2 / P3	✓	-	-	-	-	kW, MW, GW
System active power and demand	P	✓	✓	✓	✓	-	kW, MW, GW
Phase reactive power	Q1 / Q2 / Q3	✓	-	-	-	-	kvar, Mvar, Gvar
System reactive power and demand	Q	✓	✓	✓	✓	-	kvar, Mvar, Gvar
Phase apparent power	S1 / S2 / S3	✓	-	-	-	-	kVA, MVA, GVA
System apparent power and demand	S	✓	✓	✓	✓	-	kVA, MVA, GVA
Phase power factor	PF1 / PF2 / PF3	✓	-	-	-	-	-
System power factor	PF	✓	✓	✓	-	-	-
System active energy import and export	EP+ / EP-	-	-	-	-	✓	kWh, MWh, GWh
Phase active energy	L1 / L2 / L3	-	-	-	-	✓	kWh, MWh, GWh
System reactive energy bi-directional	EQ1+ / EQ-	-	-	-	-	✓	kvarh, Mvarh, Gvarh
Phase reactive energy bi-directional	L1 / L2 / L3 / Total	✓	-	-	-	✓	kVAL
System apparent energy	Total	-	-	-	-	✓	kvarh, Mvarh, Gvarh
4 Quadrant reactive energy	EQ1 / EQ2 / EQ3 / EQ4	-	-	-	-	✓	kvarh
Total harmonic distortion phase voltage	THDV1 / THDV2 / THDV3	✓	-	-	-	-	%
Total harmonic distortion phase current	THDI1 / THDI2 / THDI3	✓	-	-	-	-	%
Total system harmonic distortion voltage	Harmonic RMS → Ratio (1-63rd)	✓	-	-	-	-	%
Total system harmonic distortion current	Harmonic RMS → Ratio (1-63rd)	✓	-	-	-	-	%
Voltage unbalance, Pos, Seq Comp, Neg Seq Comp, unbalance factor	Unbalance-U	✓	-	-	-	-	V, %
Current unbalance, Pos, Seq Comp, Neg Seq Comp, unbalance factor	Unbalance-I	✓	-	-	-	-	A, %
Phase to neutral, phase to phase voltage and frequency deviation		✓	-	-	-	-	V, Hz
Fundamental wave voltage/current, harmonic voltage/current, fundamental wave active/reactive and apparent power, fundamental wave power factor	V1 / V2 / V3 / L1 / L2 / L3 P1 / P2 / P3 + Total Q1 / Q2 / Q3 + Total	✓	-	-	-	-	A, V kW, kVA
Voltage short term flicker, long term flicker and fluctuation	V1-N / V2-N / V3-N	✓	-	-	-	-	-
Phase voltage and current phase angle	L1 / L2 / L3	✓	-	-	-	-	Degree
Graphical phase voltage and current waveform		✓	-	-	-	-	-
Phasor diagram	Phasor diagram	✓	-	-	-	-	-
Phase voltage crest factor	UKPR1 / UKPR2 / UKPR3	✓	-	-	-	-	-
Phase current K factor	IK1 / IK2 / IK3	✓	-	-	-	-	-
Voltage and current phase sub harmonic content tabular and graphical 1-63	V1 / V2 / V3 I1 / I2 / I3	✓	-	-	-	✓	V, I, %
Real time clock date and time	-	✓	-	-	-	-	Day, Month, Year Second, Minute, Hour
Event recorder	-	-	-	-	-	✓	-
Recording of dips, swells and interruptions (>10ms)		-	-	-	-	✓	V
Multi-tariff energy	TOU	-	-	-	-	✓	kWh, MWh, GWh
Additional energy register		-	-	-	-	✓	kWh, MWh, GWh

## Power Quality Readings

Parameter	Accuracy
Volts unbalance	0.5%
Amps unbalance	0.5%
L-N voltage deviation	0.5%
L-L voltage deviation	0.5%
Frequency deviation	±0.01Hz
Fundamental voltage	0.5%
Fundamental current	0.5%
Harmonic voltage	0.5%
Harmonic current	0.5%
Fund active power	0.5%
Fund archive power	0.5%
Fund apparent power	0.5%
Fundamental PF	0.5%
Short term severity	S
Long term severity	S
Voltage fluctuation	A
Phase angle	±0.1°
Crest factor	0.5%
K factor	0.5%
THD V/I	Class A
Harmonic ratio	Class A
Harmonic V1	Class A
Harmonic V2	Class A
Harmonic V3	Class A
Harmonic I1	Class A
Harmonic I2	Class A
Harmonic I3	Class A
Voltage waveform	1%
Current waveform	1%
Phasor diagram	±0.1°
Rapid voltage changes	0.5%

## Display

Display Type	Full colour graphical display	
Page scrolling	Manual by front key	
Displayed parameters and accuracies	Voltage	0.1%
	Current	0.1%@ In=5A, 0.2%@ In=1A
	Frequency	±0.01Hz
	Power factor	0.1%
	Active power	Class 0.2S@In=5A , Class 0.5S@In=1A (IEC/EN62053-22)
	Reactive power	Class 2 (IEC/EN62053-23)
	Apparent power	Class 0.2S@In=5A, Class 0.5S@In=1A
	Active Energy	Class 0.2S@In=5A, Class 0.5S@In=1A (IEC/EN62053-22)
	Reactive Energy	Class 2 (IEC/EN62053-23)
	Total Harmonic Distortion	THD - up to 63rd
	Data update	1s

## Programming

Parameters that can be changed using programming menu	CT Primary current CT Secondary current VT primary voltage VT secondary voltage Communication address Communication speed (Baud) Communication Parity Communication number of stop bits Back-light time-out period Demand period (for integration) Pulse output (kWh) Reset to Factory Default Reset Energy and Maximum Demand Reset Active Energy Reset Reactive Energy Reset Apparent Energy Reset Maximum Current Reset Maximum Active Power Reset Minimum Active Power Reset Maximum Reactive Power Reset Minimum Reactive Power Reset Maximum Apparent Power Digital Input Relay Output Alarms Grid Frequency Harmonic Distortion Alarm Tariff Settings
Programming access	Password protected (user selectable)
Memory retention	Non volatile memory

## Input

Connection	Single phase, Three phase three wire, Three phase four wire - TN, TT, IT network
Input voltage range	10...400Vac (L - N) / 10...690Vac (L - L)
Voltage Rated Burden	0.2VA
Nominal current input	1A, 5A (from current transformer)
Max current (Imax)	6A (1.2 x Nominal)
Current Rated Burden	0.1VA
Starting current	10mA
Short time over-current	30 x Imax to IEC/EN62053-21 + 23
Impulse voltage withstand	6kV 1.2/50µS 0.5J
AC voltage withstand	4kV 50Hz for 1 min.
CT primary current	1...10,000A
VT primary voltage	100...10,000V
Frequency	45...65Hz

## Auxiliary Supply

Voltage range	80...270V, 50/60Hz, 100...350Vdc
Operating frequency	45...65Hz
Power consumption	≤5VA

## Interfaces

<b>Energy pulses</b>	
Number of pulse outputs	1
Pulse output function	kWh
Pulse output type	Semiconductor (does not support volt-free operation)
Pulse output Max. current	10mA
Pulse output voltage range	5...27VDC
Pulse duration	80ms ±20%
Pulse resolution	5,000, 20,000 or 80,000 pulses/kWh
<b>Communication</b>	
Communication type	RS485
Communication protocol	Modbus
Address	1...255
Number of bits	8bits
Stop bits	1 or 2
Parity	None, odd, even
Baud rate	1200, 2400, 4800, 9600, 19200, 38400bps
Required response time to request	≤100ms
Number of meters connected on the bus	32 (up to 255 with RS485 repeater)
Max distance from Master device	500M

<b>Relay output</b>	
Number of outputs	2
Relay rating	250V 5A AC1/ 30V 5A DC
Isolation	2kVac
Functional description	The relay outputs can be configured to operate in the following modes: [OFF] - the outputs are not used; [Remote] the outputs are controlled remotely via communications, [Alarm] the outputs respond to user set alarm levels.
<b>Digital Inputs</b>	
Number of inputs	2
Input type	ON: 140...270V AC, OFF: <110V AC
Isolation	2kVac
Functional description	The digital inputs can be configured to operate in the following modes: [ON-OFF] - the status of the digital inputs are displayed; [pulse-count] - each pulse of the digital input is counted and stored in a holding register; [spare energy] - when the digital input is turned ON any energy consumed is recorded in the spare energy register.

## Insulation

Installation category	Category III
Pollution degree	2
Insulation voltage rating	300V L-N

## Environmental Conditions

Reference temperature	23°C ±2°C
Specified temperature operating range	-10°C...+60°C
Storage temperature	-25°C...+70°C
Relative humidity	5...95%, non-condensing

## Mechanical

<b>Housing</b>	
Housing	DIN96
Mounting	Panel mounted (Max. panel thickness 10mm)
Tamper sealing	Terminal cover sealing
Housing material	Self-extinguishing polycarbonate (UL94 V-0)
Protection degree (IEC/EN60529)	IP64 (front panel), IP20 (meter body)
Weight	<370g
<b>Termination</b>	
Current input terminal type	Screw clamp type
Max. wire size	2.5mm <sup>2</sup>
Voltage input terminal type	Screw clamp type
Max. wire size	2.5mm <sup>2</sup>
Output terminal type	Screw clamp type
Max. wire size	2.5mm <sup>2</sup>

**Conformity**

Electromagnetic compatibility	IEC/EN61326-1, IEC/EN55011 Class A, IEC/EN61000-4-2, -3, -4, -5, -6, -8, -11
Accuracy and functionality	IEC/EN62053-21, IEC/EN62053-23, IEC/EN62053.22
Safety	IEC/EN61010-1

**Wiring Diagrams**

**Notes:** # All fuse types : 0.5A class CC UL type  
0.5A fast acting 600V

- (a) The external wiring and the system type selected in the setup must match..
- (b) Voltage and current signals must be AC signals. Do not connect DC signals to input terminals.
- (c) Voltage input: make sure the input voltage is not higher than the rated voltage of the meter, otherwise connect an external VT to the meter. If an external VT is used, meter accuracy will depend on external VT accuracy. Make sure external VT accuracy is equal to or better than that of the meter.
- (d) Current input: make sure the input current is not higher than the rated current of the meter, or connect an external CT to the meter. If an external CT is used, meter accuracy will depend on external CT accuracy. Make sure external CT accuracy is equal to or better than that of meter. If there is more than one meter connected to the CT, connect them in series. Before removing the current input wires of the meters, make sure no current is flowing through the CT or fit a shortening link to the secondary terminals.
- (e) Make sure that voltage and current inputs are connected with phase in the same sequence.

**Typical Wiring Illustration**

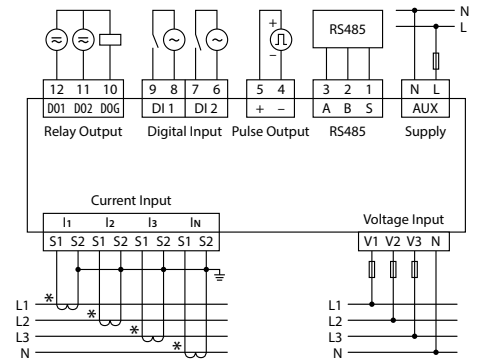

**Signal Wiring Diagrams**

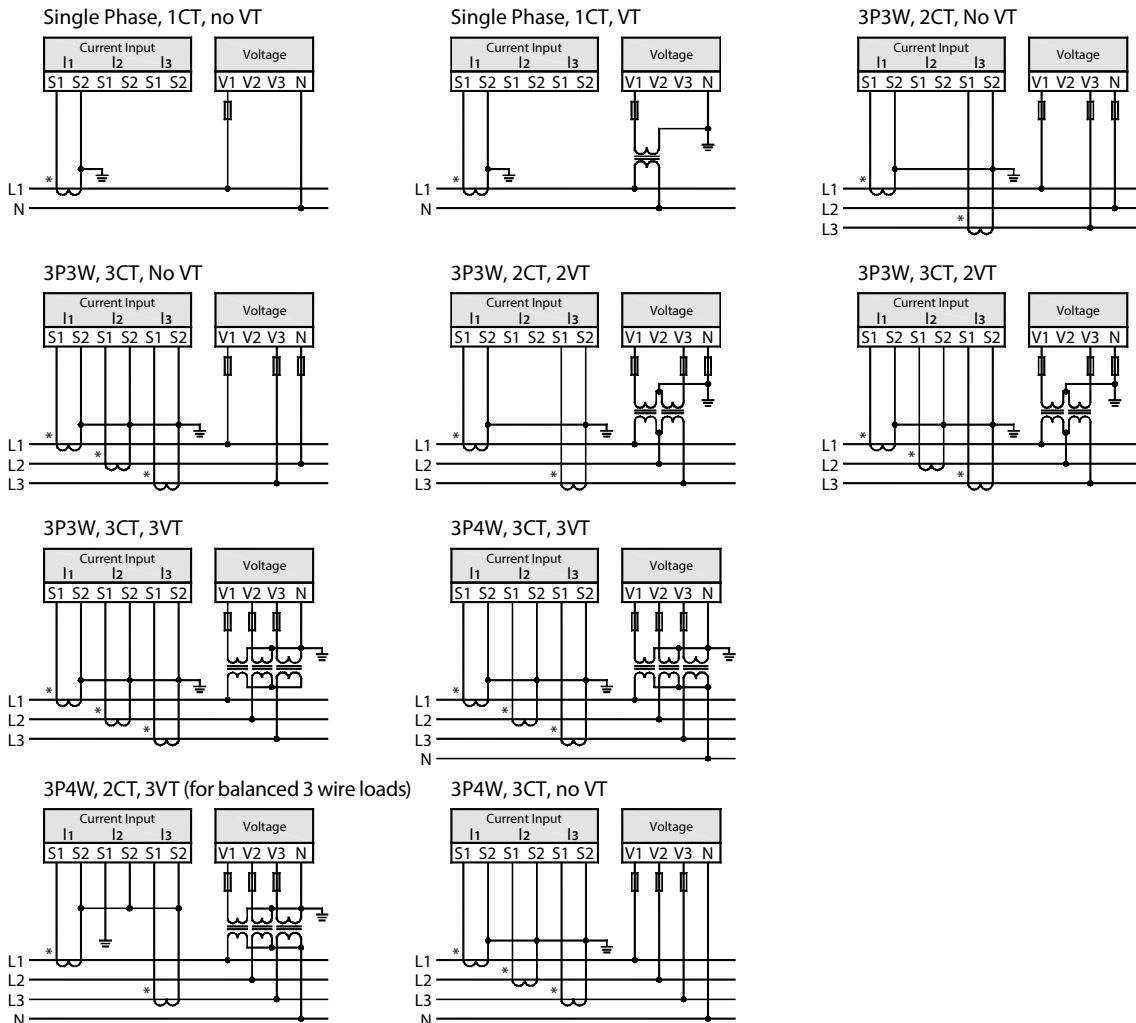

### Plug-in Modules

The RI-F550 is provided with two connection points, each of which can accommodate two extension modules. This means that up to four modules may be connected per meter.

However only one communication module can be connected to each connection point. The communication modules are RI-A5ETNT and RI-A5ETNT.

The arrangement of the modules can be set according to the users requirements.

For example:-

- Four RI-A5DCDI modules
- or
- two RI-A5DCDI modules
- + one RI-A5RO5A
- or
- one RI-A5DCDI module
- + one RI-A5DCAO module
- + one RI-A5RS485 module etc.



Module	Description
RI-A5DCDI	4 x DC digital inputs
RI-A5RO5A	2 x relay outputs
RI-A5DCAI	2 x analogue inputs : mA
RI-A5PT100	2 x analogue inputs : PT100
RI-A5DCAO	2 x analogue outputs : mA
RI-A5ETNT	Ethernet, Modbus/TCP
RI-A5PROF	DB9, Profibus-DP
RI-A5RS485	RS485, Modbus-RTU
RI-A5RSBAC	BACnet RS485
RI-A5IPBAC	BACnet TCP/IP

### Module Fitting

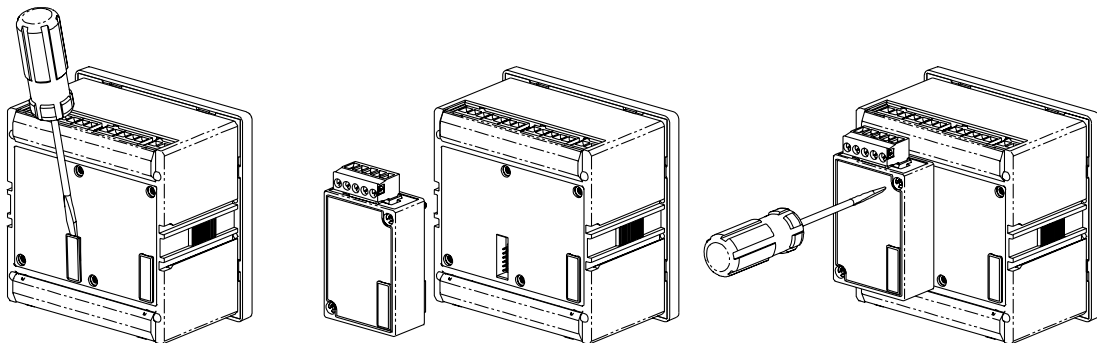

### Dimensions

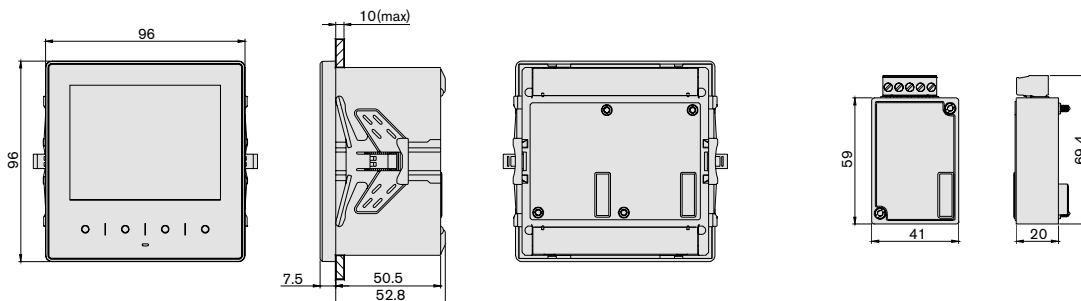

### Model Selection Table

Description	Model
Colour graphical display with touch buttons	RI-F550