

RI-CT100 Series



Single Phase Moulded Case Current Transformers

- From 400A to 2000A Primary currents
- 5A or 1A Secondary output
- 90mm width
- 60 x 30mm aperture
- Sealable terminal cover
- Supplied with Busbar fixings and mounting feet
- Compact design
- Indication of primary current flow (arrows on case body)

60 x 30mm

Product Description

The RI-CT100 Series forms part of a large family of solid core single phase moulded case current transformers from Rayleigh Instruments.

These transformers are suitable for monitoring current flow in commercial, industrial or utility applications. They are designed to connect any standard metering or relay product requiring a 5A or 1A output and are available with Primary current input ranges from 400A to 2000A

The RI-CT100 Series have been designed for ease of installation and are supplied with Busbar fixings and mounting feet. They also have clear markings moulded into the case to indicate the correct direction of primary current flow to minimise installation errors.

Parameters

Primary Current	Burden			Order Code
	Class 0.5 VA	Class 1 VA	Class 3 VA	
400	3	5	7	0400
500	3.75	5	10	0500
600	10	15	20	0600
800	15	20	25	0800
1000	15	20	25	1000
1200	15	20	25	1200
1250	15	20	25	1250
1500	15	20	25	1500
1600	15	20	25	1600
2000	20	25	30	2000

Available with 5A or 1A Secondary

Rated Standard

Rated Primary Current (I_{pr})	400...2000A
Frequency Range (f_R)	47...63Hz
Rated continuous over current (I_{cth})	1.2 x rated current
Rated short time thermal current (I_{th})	<60 I_n
Rated dynamic current (I_{dyn})	2.5 I_{th}
Instrument security factor (FS)	≤5
Rated Secondary output (I_{sr})	5A or 1A
Accuracy class	Class 0.5, 1 and 3 to IEC/EN61869-2

Insulation

Insulation type	Dry transformer, air insulation; Class B
Highest voltage (U_m)	0.72kV r.m.s.
Rated insulation level	3kV r.m.s. 50Hz/1 min

Environmental Conditions

Reference temperature	23°C ±1°C
Nominal temperature range	-25°C...50°C
Daily mean temperature	≤30°C
Limit temperature range for storage	-40°C...85°C
Relative humidity	≤85% non condensing

Housing

Housing material	Self extinguishing polycarbonate
Protection degree (IEC/EN60529)	IP40 housing, Terminals IP20
Mounting	Foot mounting or busbar mounting
Weight	≤700g

Connections

Primary winding	Passing cable
Secondary winding	Screw clamp connection - 6mm ² Max.

Dimensions (mm)

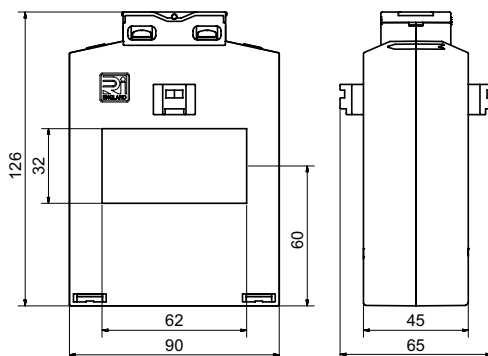

Accessories

The RI-CT100 series of current transformers come supplied with fixing feet and busbar clamping screws.



Information Required with Order

Build your order number - example	RI-CT100 5A 1600
Model	
Secondary Current	
Primary Current Range - See Parameters Table 'Order Code'	