



96 x 96

## SPECIFICATIONS

### DISPLAY

Liquid crystal display with backlight  
 4 lines, 4 digits per line to show electrical parameters  
 5th line, 8 digits to show energy  
 Bar graph for current indication

### LCD INDICATIONS

- 1** - Integration of energy
- PRG** - Unit is in configuration menu
- Communication in progress
- MAX DMD** - Maximum and Minimum Demand Power

### WIRING INPUT

3 Ø - 4 wire, 3 Ø - 3 wire, 2 Ø - 3 wire and  
 1 Ø - 2 wire system

### RATED INPUT VOLTAGE

11 to 300V AC (L-N) ;  
 19 to 519V AC (L-L) ; Installation Category III (600V)

### FREQUENCY RANGE

45-65 Hz

### RATED INPUT CURRENT

Nominal 5A AC (Min-11mA, Max-6A)

### BURDEN

0.5 VA @5A per phase

### CT PRIMARY

1A / 5A to 10,000A (Programmable for any Value)  
**Note :** 1A to 10,000A if CT secondary is 1 else  
 CT primary is 5A to 10,000A

### CT SECONDARY

1A or 5A (programmable)

### PT PRIMARY

100V to 500kV (Programmable for any value)

### PT SECONDARY

100 to 500V AC (L-L)(Programmable for any value)

### Display update time

1 sec. for all parameters

### Display Scrolling

Automatic or Manual (Programmable)

### POWER CONSUMPTION

Less than 8VA

### ENVIRONMENTAL CONDITIONS

- Indoor use
- Altitude of up to 2000 meters
- Pollution degree II

Temperature : Operating : -10°C to 55°C

Storage : -20°C to 75°C

Humidity : Up to 85% non-condensing

### PROTECTION CLASS : II

### MOUNTING : Panel mounting

### WEIGHT : 318gms

### OUTPUT

Pulse Output : Voltage range : External 24V DC max.

Current capacity : 100mA max

Pulse Width : 100 ms ± 5ms.

## ORDER CODE INFORMATION

Product	Supply	Certification
RI-F200-G-C	100 to 240V AC, -15% +12%, 50 / 60Hz, ±5%	CE
<b>Installation Category III</b>		

## SERIAL COMMUNICATION

Interface standard and protocol	RS485 and MODBUS RTU
Communication address	1 to 255
Transmission mode	Half duplex
Data types	Float and Integer
Transmission distance	500m maximum
Transmission Speed	300, 600, 1200, 2400, 4800, 9600, 19200 (in bps)
Parity	None, Odd, Even
Stop bits	1 or 2

## ACCURACY :

Measurement	Accuracy
Voltage $V_{L-N}$	±0.5% of Full scale
Voltage $V_{L-L}$	±0.5% of Full scale
Current	±0.5% of Full scale
Frequency	±0.1% For L-N Voltage >20V, For L-L Voltage >35V
Active Power	1%
Apparent power	1%
Reactive Power	1%
Power factor	±0.01
Active energy	Class 1
Reactive energy	Class 1
Apparent energy	Class 1
MAX / MIN Active Power	1%
MAX / MIN Reactive Power	1%
MAX Apparent Power	1%

## RESOLUTION :

PT Ratio x CT Ratio	kWh / kVAh / kVArh	Pulse
<15	0.01K	0.01K
<150	0.1K	0.1K
<1500	1K	1K
<15000	0.01M	0.01M
<150000	0.1M	0.1M
≥1500000	1M	1M

- NOTE :** 1) For Voltage, Current and Power, resolution is automatically adjusted.  
 2) For power factor, resolution is 0.001  
 3) **1** blinks after every 5 sec., if load is connected on any one of 3 phases.

## SAFETY PRECAUTIONS

All safety related codifications, symbols and instructions that appear in this operating manual or on the equipment must be strictly followed to ensure the safety of the operating personnel as well as the instrument.

If the equipment is not used in a manner specified by the manufacturer it might impair the protection provided by the equipment.

- Do not use the equipment if there is any mechanical damage.
- Ensure that the equipment is supplied with correct voltage.

### CAUTION :

1. Read complete instructions prior to installation and operation of the unit.
2. Risk of electric shock.
3. The equipment in its installed state must not come in close proximity to any heating sources, oils, steam, caustic vapors or other unwanted process by products.

## WIRING GUIDELINES

### WARNING :

1. To prevent the risk of electric shock, power supply to the equipment must be kept OFF while doing the wiring arrangement.
2. Wiring shall be done strictly according to the terminal layout, Confirm that all connections are correct.
3. Use lugged terminals.
4. To reduce electromagnetic interference use of wires with adequate ratings and twists of the same in equal size shall be made with shortest connections.
5. Layout of connecting cables shall be away from any internal EMI source.
6. Cable used for connection to power source, must have a cross section of 0.5mm<sup>2</sup> to 2.5mm<sup>2</sup> ( 20 to 14AWG ; 75°C (min) ). These wires shall have current carrying capacity of 6A.
7. Copper cable should be used (Stranded or Single core cable).
8. Before attempting work on device, ensure absence of voltages using appropriate voltage detection device.

## INSTALLATION GUIDELINES

### CAUTION :

1. This equipment, being built-in-type, normally becomes a part of main control panel and in such case the terminals do not remain accessible to the end user after installation and internal wiring.
2. Conductors must not come in contact with the internal circuitry of the equipment or else it may lead to a safety hazard that may in turn endanger life or cause electrical shock to the operator.
3. Circuit breaker or mains switch must be installed between power source and supply terminals to facilitate power 'ON' or 'OFF' function. However this switch or breaker must be installed in a convenient position normally accessible to the operator.
4. Before disconnecting the secondary of the external current transformer from the equipment, make sure that the current transformer is short circuited to avoid risk of electrical shock and injury.
5. The equipment shall not be installed in environmental conditions other than those mentioned in this manual.
6. The equipment does not have a built-in-type fuse. Installation of external fuse of rating 275V AC / 0.5Amp for electrical circuitry / battery is highly recommended.

## MECHANICAL INSTALLATION

For installing the meter

1. Prepare the panel cutout with proper dimensions as shown below.
2. Push the meter into the panel cutout. Secure the meter in its place by fitting the clamp on the rear side. Fit clamps on both sides in diagonally opposite location for optimum fitting.
3. For proper sealing, tighten the screws evenly with required torque.  
 Terminal screw tightening torque :  
 0.68 N-m to 0.79 N-m ( 6.018 In-Lb to 6.992 In-Lb )  
 Screw clamp tightening torque : 0.1N-m (0.885 Lb-inch)

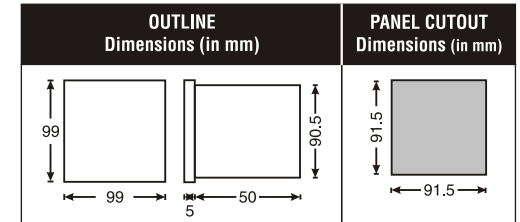

## MAINTENANCE

1. The equipment should be cleaned regularly to avoid blockage of ventilating parts.
2. Clean the equipment with a clean dry or damp cloth. Do not use any cleaning agent other than water.

## TERMINAL CONNECTIONS

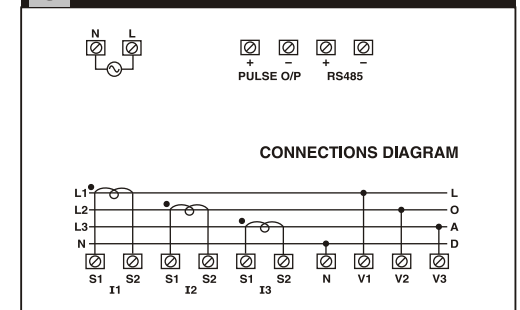

## FRONT PANEL DESCRIPTION

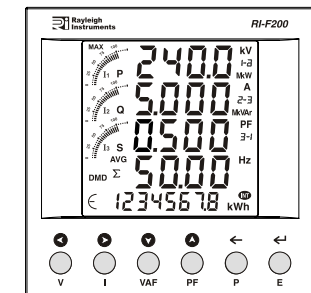

## ONLINE PAGE DESCRIPTION

There are 6 dedicated keys labelled as V, I, VAF, PF, P, E. Use these 6 keys to read meter parameters. Simply press these keys to read the parameters.

KEY PRESS	ONLINE PAGE DESCRIPTION
Press "V"	<p><b>The first screen :</b> Displays line to neutral Voltage of three phase and average line to neutral voltage.</p> <p><b>The second screen :</b> Displays line to line voltage of three phase and average line to line voltage.</p> <p><b>The third screen :</b> Displays total percentage harmonics of line to neutral voltage of three phase and average line to neutral voltage.</p> <p><b>The fourth screen :</b> Displays total percentage harmonics of line to line voltage of three phase and average line to line voltage.</p> <p><b>The fifth screen :</b> Press for 3 sec, Displays phase sequence indication.</p> <p><b>Note :</b> 1) For 3 Ø 3 wire system, for only the second and forth screen will be available. 2) In 1 Ø 2 wire system only first, third and fifth screen will be available.</p>
Press "I"	<p><b>The first screen :</b> Displays phase current of three phase and neutral current.</p> <p><b>The second screen :</b> Displays phase maximum current demand of three phase and average current .</p> <p><b>The third screen :</b> Displays total percentage harmonic of current of three phase and average phase current.</p> <p><b>The fourth screen :</b> Press for 3 sec, Displays current correction indication page.</p> <p><b>Note :</b> For 3 Ø 3 wire system only first, second and third screen will be available. Displays average current instead of neutral current.</p>
Press "VAF"	<p><b>The first screen :</b> Displays voltage, current, power factor of first phase and frequency.</p> <p><b>The second screen :</b> Displays voltage, current, power factor of second phase and frequency.</p> <p><b>The third screen :</b> Displays voltage, current, power factor of third phase and frequency.</p> <p><b>The fourth screen :</b> Displays average value of voltage, current and power factor of three phase and frequency.</p> <p><b>Note :</b> 1) In 3 Ø 3 wire system voltage current power factor and freq. will be line to line. 2) In 1 Ø 2 wire system only first screen will be available.</p>
Press "PF"	<p><b>The first screen :</b> Displays power factor of three phase and average power factor.</p> <p><b>Note :</b> For 3 Ø 3 wire system, only average power factor will be available on this screen.</p>
Press "P"	<p><b>The first screen :</b> Displays active power of three phase and total active power.</p> <p><b>The second screen :</b> Displays reactive power of three phase and total reactive power.</p> <p><b>The third screen :</b> Displays apparent power of three phase and total apparent power.</p> <p><b>The fourth screen :</b> Displays active, reactive, apparent power and power factor of first phase.</p> <p><b>The fifth screen :</b> Displays active, reactive, apparent power and power factor of second phase.</p> <p><b>The sixth screen :</b> Displays active, reactive, apparent power and power factor of third phase.</p> <p><b>The seventh screen :</b> Displays total active, reactive, apparent power and average power factor of three phase.</p> <p><b>The eighth screen :</b> Displays maximum active power demand, reactive power demand and apparent power demand.</p> <p><b>The ninth screen :</b> Displays minimum active power demand and reactive power demand.</p> <p><b>Note :</b> 1) For 3 Ø 3 wire system only seventh, eighth and ninth screen will be available. 2) In 1 Ø 2 wire system only first, second, third, fourth, eighth and ninth screen will be available.</p>
Press "E"	<p><b>The first screen :</b> Displays active energy of three phase.</p> <p><b>The second screen :</b> Displays apparent energy of three phase.</p> <p><b>The third screen :</b> Displays reactive energy of three phase.</p>

**Note :** For 1 phase 2 wire network, all page will be same as 3 phase 4 wire but only selected phase parameter will display.

### AUTOMATIC / MANUAL MODE DESCRIPTION

Press E (←) button for 3 seconds to toggle between Automatic and Manual mode.  
**Note :** By default unit operates in automatic mode. In automatic mode online pages scroll automatically at the rate of 5 seconds per page.  
 In automatic mode when any key is pressed, unit temporarily switches to manual mode and the appropriate page is displayed, also if any key is not pressed for 5 sec, unit resumes automatic mode.

### SERIAL NUMBER DESCRIPTION

Press PF (▲) key for 10sec. to display 8 digit serial number only for 10sec. at 5th line of display

### CONFIGURATION

There are 6 dedicated keys with symbols marked as ◀, ▶, ▼, ▲, ←, →. use these 6 keys to enter into configuration menu / change setting.

**Note :** The settings should be done by a professional, after going through this users manual and after having understood the application situation.

For the configuration setting mode :

- Use ▲ + ▼ keys for 3 sec. to enter or exit from the configuration menu.
- Use ◀ or ▶ keys to move cursor left or right by one digit each time.
- Use ▲ or ▼ keys for increasing or decreasing parameters value.
- Use ← key to go back to previous page.
- Use → key to save the setting and move on to next page.

Config. page	Function	Range or Selection	Factory Setting
	Password	0000 to 9998	1000
1	Change Password	No / Yes	No
1.1	New Password	0000 to 9998	1000
2	Network Selection	3P4W, 3P3W, 1P2W-P1, 1P2W-P2 and 1P2W-P3	3P4W
3	CT Secondary	1A or 5A	5
4	CT Primary	1A, 5A to 10,000A	5
5	PT Secondary	100V to 500V	350
6	PT primary	100V to 500kV	350
7	Slave Id	1 to 255	1
8	Baud Rate	300, 600, 1200, 2400, 4800, 9600 and 19200 (bps)	9600
9	Parity	None, Odd, Even	None
10	Stop Bit	1 or 2	1
11	Back Light	0 to 7200 sec.	0000
12	Demand interval method	Sliding / Fixed	Sliding
13	Demand interval duration	1 to 30	15
14	Demand interval length	1 to 30 min	1

Config page.	Function	Range or Selection	Factory Setting
15	Max Page Auto	1 to 21	21
16	Change Page Sequence	No / Yes	No
16.01	Page sequence 1	1 to 21	1
16.02	Page sequence 2	1 to 21	2
16.03	Page sequence 3	1 to 21	3
16.04	Page sequence 4	1 to 21	4
16.05	Page sequence 5	1 to 21	5
16.06	Page sequence 6	1 to 21	6
16.07	Page sequence 7	1 to 21	7
16.08	Page sequence 8	1 to 21	8
16.09	Page sequence 9	1 to 21	9
16.10	Page sequence 10	1 to 21	10
16.11	Page sequence 11	1 to 21	11
16.12	Page sequence 12	1 to 21	12
16.13	Page sequence 13	1 to 21	13
16.14	Page sequence 14	1 to 21	14
16.15	Page sequence 15	1 to 21	15
16.16	Page sequence 16	1 to 21	16
16.17	Page sequence 17	1 to 21	17
16.18	Page sequence 18	1 to 21	18
16.19	Page sequence 19	1 to 21	19
16.20	Page sequence 20	1 to 21	20
16.21	Page sequence 21	1 to 21	21
17	Pulse weight (kWh)	0.01 to 99.99	0.01
18	Pulse duration (Sec)	0.1 to 2.0	0.1
19	Factory default	No / Yes	No
20	Reset energy and MAX demand	No / Yes	No
20.1	Password	0001 to 9999	1001
20.01	Reset active energy	No / Yes	No
20.02	Reset reactive energy	No / Yes	No
20.03	Reset apparent energy	No / Yes	No
20.04	Reset MAX current	No / Yes	No
20.05	Reset MAX active power	No / Yes	No
20.06	Reset MIN active power	No / Yes	No
20.07	Reset MAX Reactive power	No / Yes	No
20.08	Reset MIN Reactive power	No / Yes	No
20.09	Reset MAX apparent power	No / Yes	No

- For resetting energy parameters user will be prompted the password. If correct password is entered, the user will be able to reset all energy parameters. This password will be value which will be greater than the configuration password by 1.

### NETWORK SELECTION AND WIRING INPUT

Network selection in configuration mode	Wiring
3P4W	3P4W, 2P3W, 1P2W (P1/P2/P3)
3P3W	3P3W

**Note :** P1, P2 and P3 are Three Phase.

### APPLICATION OF PULSE OUTPUT

#### ● PROCESS INTEGRATION

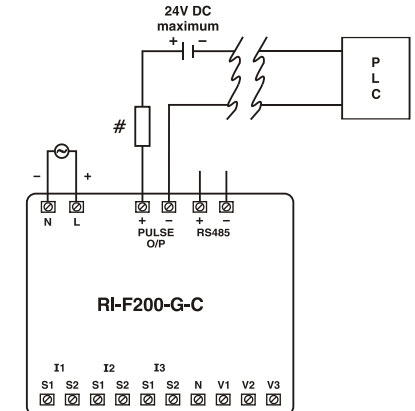

Pulse output from RI-F200-G-C meter can be interfaced into a process through a PLC for on line control of energy content in the process. If the PLC has a self excited digital input, external DC supply is not needed. The kWh pulse is also used to derive average kWh information at the PLC.

#### ● ENERGY CONTROLLER

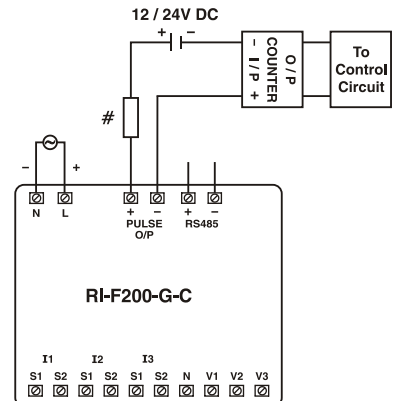

Pulse output from RI-F200-G-C meter can be used as alarm generator or total energy controller by interfacing it with Pre-settable counter and control circuits (Contactors, Relay, Trip Circuit).

The counter is loaded with the maximum energy consumption. When count reaches setpoint it provides output to control circuit to take appropriate action.

**Note :** + and - is applicable only for 24V product

# All fuse types : 0.5A class CC UL type  
0.5A fast acting 600V

## MODBUS REGISTER ADDRESSES LIST

Readable parameters for Communication Model Only : [ Length (Register) : 2 ; Data Structure : Float ]

Address	Hex Address	Parameter
30000	0x00	Voltage V1N
30002	0x02	Voltage V2N
30004	0x04	Voltage V3N
30006	0x06	Average Voltage LN
30008	0x08	Voltage V12
30010	0x0A	Voltage V23
30012	0x0C	Voltage V31
30014	0x0E	Average Voltage LL
30016	0x10	Current I1
30018	0x12	Current I2
30020	0x14	Current I3
30022	0x16	Average Current
30024	0x18	kW1
30026	0x1A	kW2
30028	0x1C	kW3
30030	0x1E	kVA1
30032	0x20	kVA2
30034	0x22	kVA3
30036	0x24	kVAr1
30038	0x26	kVAr2
30040	0x28	kVAr3
30042	0x2A	Total kW
30044	0x2C	Total kVA
30046	0x2E	Total kVAr
30048	0x30	PF1
30050	0x32	PF2
30052	0x34	PF3
30054	0x36	Average PF
30056	0x38	Frequency
30058	0x3A	kWh
30060	0x3C	kVAh
30062	0x3E	kVArh

Formula to find address of individual Harmonic

Constant Parameter	Meaning
0	Voltage V1N
1	Voltage V2N
2	Voltage V3N
3	Voltage V12
4	Voltage V23
5	Voltage V31
6	Current I1
7	Current I2
8	Current I3

Address	Hex Address	Parameter
30064	0x40	kW MAX Active Power
30066	0x42	kW MIN Active Power
30068	0x44	kVAr MAX Reactive Power
30070	0x46	kVAr MIN Reactive Power
30072	0x48	kVA MAX Apparent Power
30122	0x7A	Neutral Current
		Total Harmonic Distortion (THD)
30124	0x7C	THD of Voltage V1N
30126	0x7E	THD of Voltage V2N
30128	0x80	THD of Voltage V3N
30130	0x82	THD of Voltage V12
30132	0x84	THD of Voltage V23
30134	0x86	THD of Voltage V31
30136	0x88	THD of Current I1
30138	0x8A	THD of Current I2
30140	0x8C	THD of Current I3
30684	0x2AC	Serial number of unit
30692	0x2B4	MAX I1 Demand
30694	0x2B6	MAX I2 Demand
30696	0x2B8	MAX I3 Demand
30698	0x2BA	MAX Avg. I Demand
30700	0x2BC	Phase Sequence Indication ( 0-OK clockwise, 1-Anticlockwise, 2-Invalid)
30702	0x2BE	Existing KW MAX Active Power
30704	0x2C0	Existing KW MIN Active Power
30706	0x2C2	Existing KVAr MAX Reactive Power
30708	0x2C4	Existing KVAr MIN Reactive Power
30710	0x2C6	Existing KVA MAX Apparent Power
30712	0x2C8	Existing MAX I1 Demand
30714	0x2CA	Existing MAX I2 Demand
30716	0x2CC	Existing MAX I3 Demand
30718	0x2CE	Existing MAX Avg. I Demand

$[143 + ((\text{Harmonic no}-2) \times 2) + 60 \times \text{Constant Parameter}]$

For Example,

To find the 14<sup>th</sup> Harmonic address of Voltage V31 following formula can be used :

Formula with the parameter :

$[143 + ((\text{Harmonic no}-2) \times 2) + 60 \times \text{C P}]$   
Eg.  $[143 + ((14-2) \times 2) + 60 \times 5] = 467$

So, Check the 14<sup>th</sup> Harmonic of Voltage V31 at 467 address.

Readable / writable parameters for Communication Model Only :

Address	Hex Address	Parameter	Range		Length (Register)	Data Structure
			Min value	Max value		
40000	0x00	Password	0	9998	1	Integer
			<b>Value</b>	<b>Meaning</b>		
40001	0x01	N/W selection	0	3P-4W	1	Integer
			1	3P-3W	1	Integer
			2	1P2W-P1	1	Integer
			3	1P2W-P2	1	Integer
			4	1P2W-P3	1	Integer

MODBUS register addresses list *continued*

Readable / writable parameters for Communication Model Only :

Address	Hex Address	Parameter	Range		Length (Register)	Data Structure
			Min value	Max value		
40002	0x02	CT Secondary (A)	1	5	1	Integer
40003	0x03	CT primary (CT Secondary = 5) (A)	5	10000	1	Integer
		CT primary (CT Secondary = 1) (A)	1	10000		
40004	0x04	PT Secondary (V)	100	500	1	Integer
40005	0x05	PT primary (V)	100	500000	2	Integer
40007	0x07	Slave id	1	255	1	Integer
			<b>Value</b>	<b>Meaning</b>		
40008	0x08	Baud rate (bps)	0x0000	300	1	Integer
			0x0001	600		
			0x0002	1200		
			0x0003	2400		
			0x0004	4800		
			0x0005	9600		
			0x0006	19200		
			<b>Value</b>	<b>Meaning</b>		
40009	0x09	Parity	0x0000	None	1	Integer
			0x0001	Odd		
			0x0002	Even		
40010	0x0A	Stop bit	0x0000	1	1	Integer
			0x0001	2		
40011	0x0B	Backlight OFF (sec.)	0	7200	1	Integer
40012	0x0C	Factory Default	1	Set to factory setting range	1	Integer
40013	0x0D	Reset kWh	1	Reset Total Active Energy	1	Integer
40014	0x0E	Reset kVAh	1	Reset Total Apparent Energy	1	Integer
40015	0x0F	Reset kVArh	1	Reset Total Reactive Energy	1	Integer
			<b>Min value</b>	<b>Max value</b>		
40016	0x10	Auto Mode Pages	1	21	1	Integer
			<b>Page No</b>	<b>Meaning</b>		
40017	0x11	Page Address Sequence	1- 21	1- First Page ; 21-Last Page	1	Integer
40018	0x12	Page Address Sequence	1- 21	1- First Page ; 21-Last Page	1	Integer
40019	0x13	Page Address Sequence	1- 21	1- First Page ; 21-Last Page	1	Integer
40020	0x14	Page Address Sequence	1- 21	1- First Page ; 21-Last Page	1	Integer
40021	0x15	Page Address Sequence	1- 21	1- First Page ; 21-Last Page	1	Integer
40022	0x16	Page Address Sequence	1- 21	1- First Page ; 21-Last Page	1	Integer
40023	0x17	Page Address Sequence	1- 21	1- First Page ; 21-Last Page	1	Integer
40024	0x18	Page Address Sequence	1- 21	1- First Page ; 21-Last Page	1	Integer
40025	0x19	Page Address Sequence	1- 21	1- First Page ; 21-Last Page	1	Integer
40026	0x1A	Page Address Sequence	1- 21	1- First Page ; 21-Last Page	1	Integer
40027	0x1B	Page Address Sequence	1- 21	1- First Page ; 21-Last Page	1	Integer
40028	0x1C	Page Address Sequence	1- 21	1- First Page ; 21-Last Page	1	Integer
40029	0x1D	Page Address Sequence	1- 21	1- First Page ; 21-Last Page	1	Integer
40030	0x1E	Page Address Sequence	1- 21	1- First Page ; 21-Last Page	1	Integer
40031	0x1F	Page Address Sequence	1- 21	1- First Page ; 21-Last Page	1	Integer
40032	0x20	Page Address Sequence	1- 21	1- First Page ; 21-Last Page	1	Integer
40033	0x21	Page Address Sequence	1- 21	1- First Page ; 21-Last Page	1	Integer
			<b>Value</b>	<b>Meaning</b>		
40034	0x22	Demand Interval Method	0X0000	Sliding	1	Integer
			0X0001	Fixed		
40035	0x23	Demand Interval Duration	Min Value : 1	Max Value : 30	1	Integer
40036	0x24	Demand Interval Length(min)	Min Value : 1	Max Value : 30	1	Integer
40037	0x25	Reset MAX kW	1	Reset MAX Active power	1	Integer
40038	0x26	Reset MIN kW	1	Reset MIN Active power	1	Integer



## MODBUS REGISTER ADDRESSES LIST

MODBUS register addresses list *continued*

Readable / writable parameters Communication Model Only :

Address	Hex Address	Parameter	Range		Length (Register)	Data Structure
40039	0x27	Reset MAX kVAr	1	Reset MAX Reactive power	1	Integer
40040	0x28	Reset MIN kVAr	1	Reset MIN Reactive power	1	Integer
40041	0x29	Reset MAX kVA	1	Reset MAX Apparent power	1	Integer
40054	0x36	Page address Sequence	1-21	1- First Page ; 21-Last Page	1	Integer
40055	0x37	Page address Sequence	1-21	1- First Page ; 21-Last Page	1	Integer
40057	0x39	Pulse duration (Sec)	0.1	2	1	Integer
40058	0x3A	Pulse Weight (kWh)	0.01	99.99	1	Integer
40059	0x3B	Page address Sequence	1-21	1- First Page ; 21-Last Page	1	Integer
40060	0x3C	Page address Sequence	1-21	1- First Page ; 21-Last Page	1	Integer
40064	0x40	Reset MAX Current	1	Reset MAX Current	1	Integer

## TYPICAL WIRING DIAGRAM

### 3 PHASE 4-WIRE (COMMONLY USED)

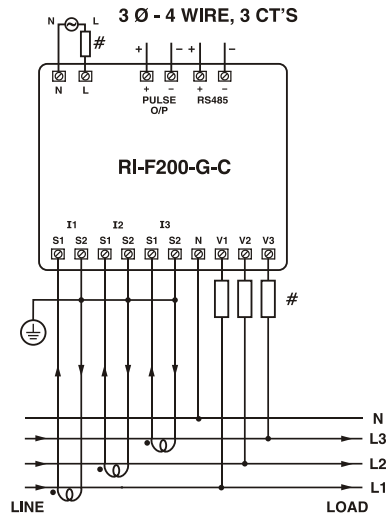

### 3 PHASE 3-WIRE

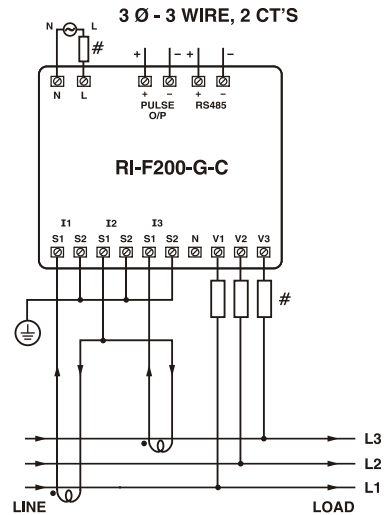

### 3 Ø - 4 WIRE, 3 CT'S and 3 PT'S

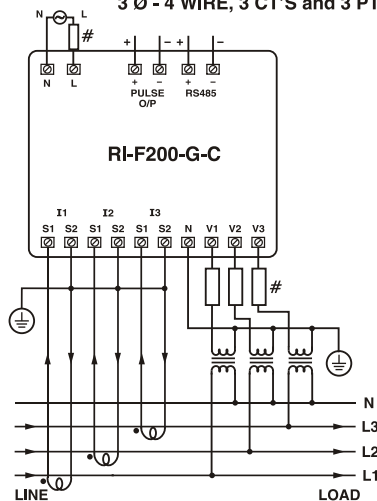

### 3 Ø - 3 WIRE, 2 CT'S and 2 PT'S

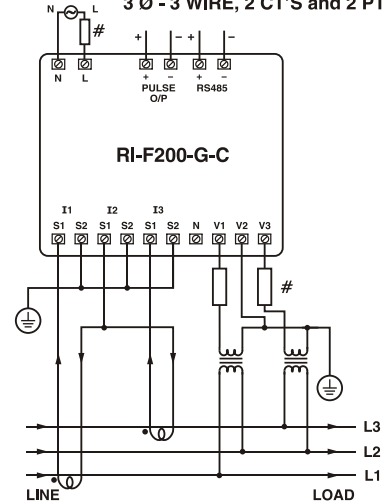

### 2 PHASE - 3 WIRE

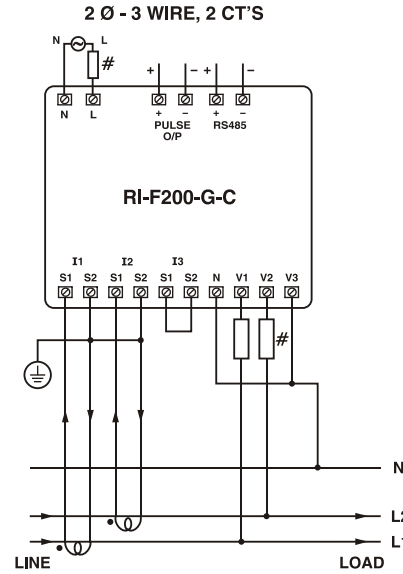

### 1 PHASE - 2 WIRE

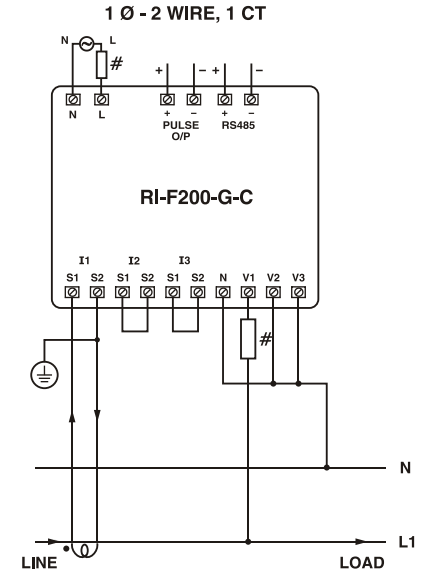

### 2 Ø - 3 WIRE, 2 CT'S and 2 PT'S

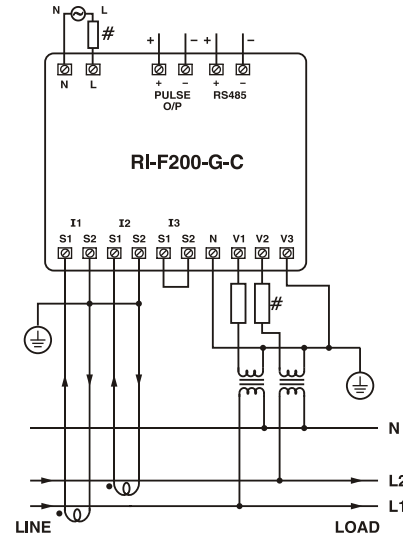

# All fuse types : 0.5A class CC UL type  
0.5A fast acting 600V

### CONNECTION DIAGRAM FOR COMMUNICATION

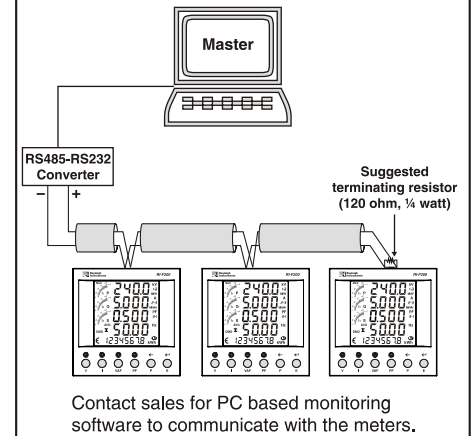

(Specifications subject to change as development is a continuous process.)

**Rayleigh  
Instruments**  
www.rayleigh.co.uk