



EAN code
 CRM-91 /230V: 8595188112444
 CRM-91 /UNI: 8595188112420
 CRM-93H /230V: 8595188112789
 CRM-93H /UNI: 8595188112468
 CRM-9S /UNI: 8595188116008



- Multifunction time relay can be used for electrical appliances, control of lights, heating, motors, pumps and fans (10 functions, 10 time ranges, multi-voltage, 16 A or 3x8 A contacts)
- Fulfills all requirements for time relays
- 10 functions:
 - 5 time functions controlled by supply voltage
 - 4 time functions controlled by control input
 - 1 function of latching relay
- Comfortable and well-arranged function and time-range setting by rotary switches
- Time scale 0.1 s - 10 days divided into 10 ranges: (0.1 s - 1 s / 1 s - 10 s / 0.1 min - 1 min / 1 min - 10 min / 0.1 hrs - 1 hrs / 1 hrs - 10 hrs / 0.1 day - 1 day / 1 day - 10 days / only ON / only OFF)
- **CRM-91H, CRM-93H:** Universal supply voltage AC/DC 12 - 240 V or AC 230 V,
 Output contact: CRM-91H: 1x changeover/SPDT 16 A; CRM-93H: 3 x changeover/SPDT 8 A
- **CRM-9S:** Universal supply voltage AC 12 - 240 V AC 12 - 240 V, absolutely noise-less switching
 1x static contactless output (triac) 01.7 A (60A/<10 ms), switches potential A1
- Multifunction red LED output indicator flashes or shines depending on the status of output
- 1-MODULE, DIN rail mounting

Technical parameters	CRM-91H	CRM-93H	CRM-9S
Number of functions:	10		
Supply terminals:	A1 - A2		
Voltage range:	UNI AC/DC 12 - 240 V (AC 50 - 60 Hz)	AC 12-240V (50-60Hz)	
Burden:	AC 0.7 - 3 VA / DC 0.5 - 1.7 W		AC max. 0.35VA
Voltage range:	230 AC 230 V / 50 - 60 Hz	x	
Consumption (apparent/loss):	AC max. 12VA / 1.3W	AC max. 12VA / 1.9W	x
Supply voltage tolerance:	-15 %; +10 %		
Supply indication:	green LED		
Time ranges:	0.1 s - 10 days		
Time setting:	rotary switch and potentiometer		
Time deviation:	5 % - mechanical setting		
Repeat accuracy:	0.2 % - set value stability		
Temperature coefficient:	0.01 % / °C, at = 20 °C (0.01 % / °F, at = 68 °F)		
Output			
Number of contacts:	1x changeover/SPDT (AgNi / Silver Alloy)	3x changeover/SPDT (AgNi / Silver Alloy)	1x static contactless output (triac)
Current rating:	16A / AC1	8A / AC1	0.7A
Breaking capacity:	4000VA / AC1, 384W / DC	2000VA / AC1, 192W / DC	x
Inrush current:	30A / <3s	10A / <3s	60A / <10ms
Switching voltage:	250V AC1 / 24V DC		x
Min. breaking capacity DC:	500mA		x
Voltage drop on switch:	x		max. 0.9 V at I max.
Load on B1 terminal:	x		Yes / I max. 0.7 A
Output indication:	multifunction red LED		
Mechanical life:	3x10 ⁷		> 10 ⁸
Electrical life (AC1):	0.7x10 ⁵		> 10 ⁸
Controlling			
Power on control input:	AC 0.025 - 0.2 VA / DC 0.1 - 0.7 W (UNI), AC 0.53 VA (AC 230 V), AC 0.025 - 0.2 VA (AC 12 - 240 V)		
Load between S-A2:	YES		
Control. terminals:	A1-S		
Glow tubes connections:	YES		NO
Max. amount of glow lamps connected to controlling input:	UNI - glow lamps cannot connected/NO 230 V - max.20 pcs (Measured with glow lamp 0.68mA/230V AC)		glow lamps cannot connected/NO
Impulse length:	min. 25 ms / max. unlimited		x
Reset time:	max. 150 ms		max. 250 ms
Other information			
Operating temperature:	-20 °C to +55 °C (-4 °F to 131 °F)		
Storage temperature:	-30 °C to +70 °C (-22 °F to 158 °F)		
Electrical strength:	4kV(supply-output)		x
Operating position:	any		
Mounting/DIN rail:	DIN rail EN 60715		
Protection degree:	IP 40 from front panel / IP 20 terminals		
Overvoltage category:	III.		
Pollution degree:	2		
Max. cable size (mm ²):	solid wire max. 1x 2.5 or 2x1.5/ with sleeve max. 1x2.5 (AWG 12)		
Dimensions:	90 x 17.6 x 64 mm (3.5" x 0.7" x 2.5")		
Weight:	(UNI) - 64 g (2.26 oz.); (230) - 62 g (2.2 oz.)	(UNI) - 89 g (3.1 oz.); (230) - 87 g (3 oz.)	51 g (1.8 oz.)
Standards:	EN 61812-1, EN 61010-1		

Symbol Connection

CRM-91H

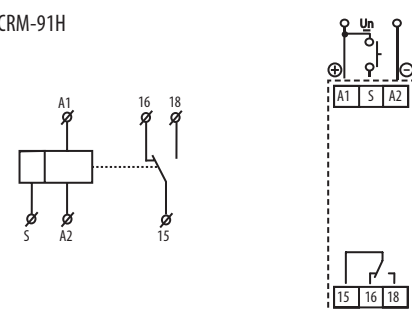

CRM-93H

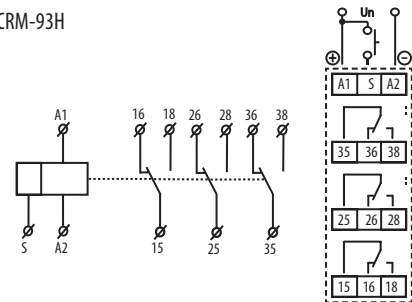

Possibility to connect load onto controlling input

It is possible to connect the load (e.g.: contactor) between terminals S-A2, without any interruption of correct relay function.

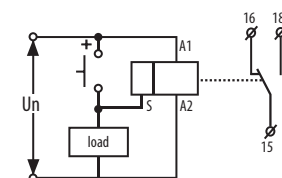

CRM-9S

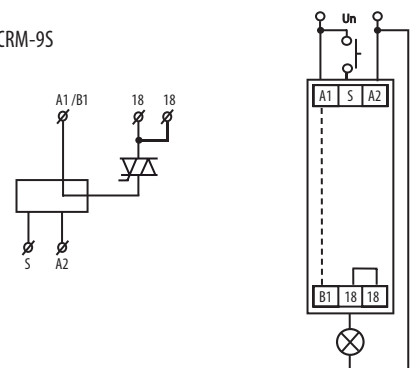



Function

On Delay (Power On)

When the input voltage U is applied, timing delay t begins. Relay contacts R change state after time delay is complete. Contacts R return to their shelf state when input voltage U is removed. Trigger switch is not used in this function.



Single Shot

Upon application of input voltage U, the relay is ready to accept trigger signal S. Upon application of the trigger signal S, the relay contacts R transfer and the preset time t begins. During time-out, the trigger signal S is ignored. The relay resets by applying the trigger switch S when the relay is not energized.

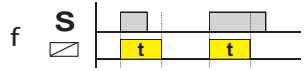

Off Delay

When input voltage U is applied, relay contacts R change state immediately and timing cycle begins. When time delay is complete, contacts return to their shelf state. When input voltage U is removed, contacts will also return to their shelf state. Trigger switch is not used in this function.

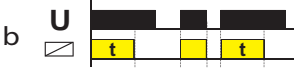

Single Shot Trailing Edge (Non-Retriggerable)

Upon application of input voltage U, the relay is ready to accept trigger signal S. Upon application of the trigger signal S, the relay contacts R transfer and the preset time t begins. At the end of the preset time t, the relay contacts R return to their normal condition unless the trigger switch S is opened and closed prior to time-out t (before preset time elapses). Continuous cycling of the trigger switch S at a rate faster than the preset time will cause the relay contacts R to remain closed. If input voltage U is removed, relay contacts R return to their shelf state.

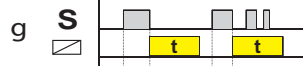

Repeat Cycle (Starting Off)

When input voltage U is applied, timing delay t begins. When time delay t is complete, relay contacts R change state for time delay t. This cycle will repeat until input voltage U is removed. Trigger switch is not used in this function.



On/Off Delay

Input voltage U must be applied continuously. When trigger switch S is closed, time delay t begins. When time delay t is complete, relay contacts R change state and remain transferred until trigger switch S is opened. If input voltage U is removed, relay contacts R return to their shelf state.

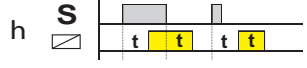

Repeat Cycle (Starting On)

When input voltage U is applied, relay contacts R change state immediately and time delay t begins. When time delay t is complete, contacts return to their shelf state for time delay t. This cycle will repeat until input voltage U is removed. Trigger switch is not used in this function.



Latching relay

Input voltage U must be applied continuously. Output changes state with every trigger switch S closure. If input voltage U is removed, relay contacts R return to their shelf state.

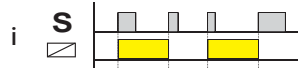

Off Delay (S Break)

Input voltage U must be applied continuously. When trigger switch S is closed, relay contacts R change state. When trigger switch S is opened, delay t begins. When delay t is complete, contacts R return to their shelf state. If trigger switch S is closed before time delay t is complete, then time is reset. When trigger switch S is opened, the delay begins again, and relay contacts R remain in their energized state. If input voltage U is removed, relay contacts R return to their shelf state.

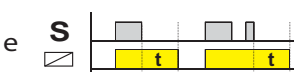

Pulse generator

Upon application of input voltage U, a single output pulse of 0.5 seconds is delivered to relay after time delay t. Power must be removed and reapplied to repeat pulse. Trigger switch is not used in this function.



Time ranges

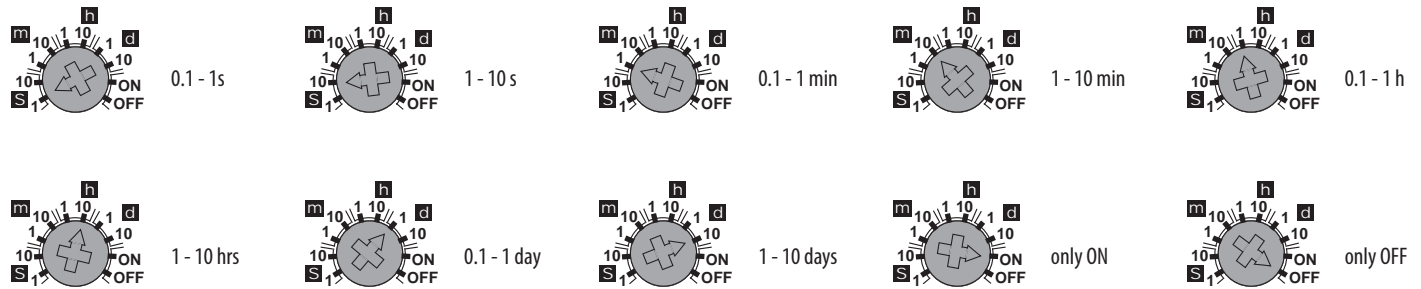

Description

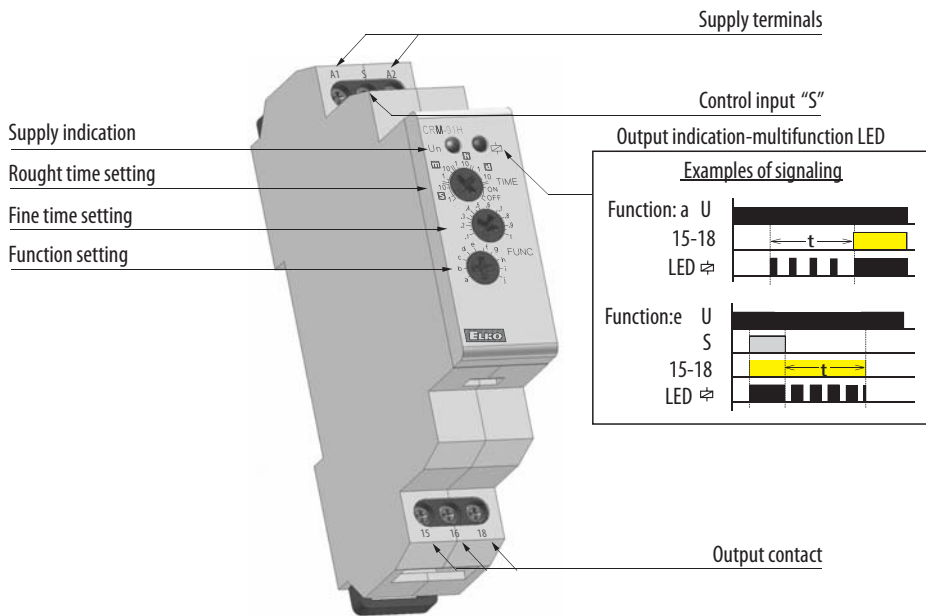

Notes

- 1) Output contacts of CRM-93H do not allow switching of different phases or 3-phase voltages (voltage > 250 V).
- 2) When mounting into steal-plated switchboards, it is necessary to keep a safety distance of min. 3 mm from terminal's screws 35-36-38 and 25-26-28 towards the shutter of a switchboard.